

Data Sheet Specification of U-Straw (125 ml)

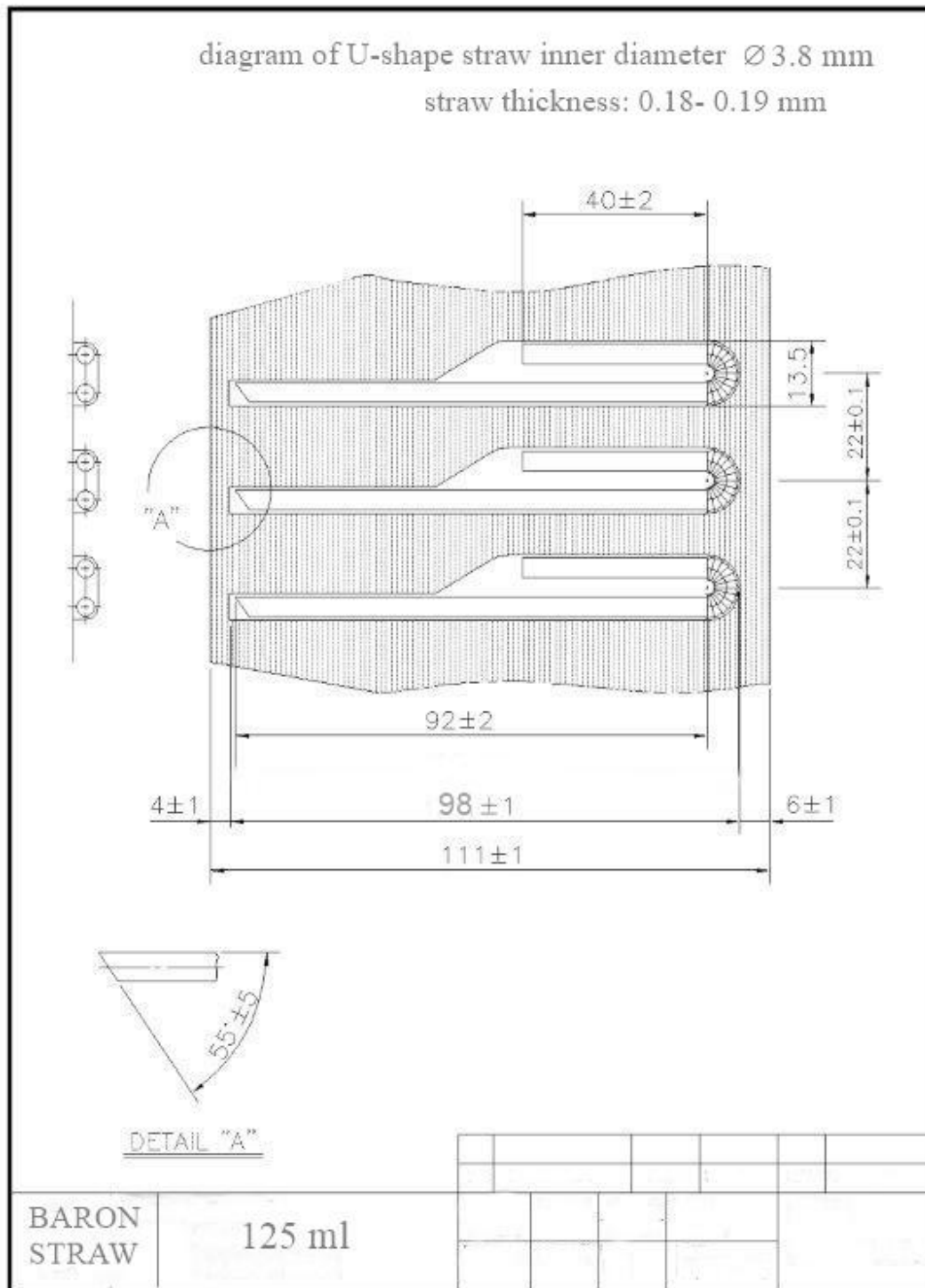

Data Sheet Specification of U-Straw (125 ml)



Technical specification 125 ml				
Property	Minimum	Target	Maximum	Criticality
1- Color		Milky White		Major
2- Material	100% Polypropylene			
3- Inner diameter (mm)	3.8	3.85	3.9	Critical
4- Straw thickness (mm)	0.18	0.19	0.2	Critical
5- Outer tube diameter (mm)	4.16	4.23	4.3	Critical
6- Length when folded (mm)	97	98	99	Major
7- Length when extended (mm)	151	152	153	Major
8- Corrugation Length (mm) when fully extended	18	20	22	Major
9- Pitch (10 straws) (mm)	218	220	222	Critical
10- Pitch between 2 straws (mm)	21.8	22	22.2	Critical
11- Upper length (mm)	38	40	42	Critical
12- Lower length (mm)	90	92	94	Critical
13- Diagonal Cutting	50	≤55	60	Major
14- Weight of straw (g)		0.41		
15- OPP film thickness in non-sealing areas (micron)		15		Critical
16- OPP film upper thickness limit	0.075		0.09	Major
17- OPP film center thickness limit	0.027		0.033	Major

Data Sheet Specification of U-Straw (125 ml)



Technical specification 125 ml				
Property	Minimum	Target	Maximum	Criticality
18- OPP film lower thickness limit	0.06		0.075	Major
19- OPP film tensile strength (ASTM D882) N/mm2 MD	120	≤140	150	Critical
20- OPP film tensile strength (ASTM D882) N/mm2 TD	230	≤250	295	Major
21- OPP film dynamic COF (ASTM D1894) NT/NT	0.18	≤0.2	0.53	Major
22- Film Material	Oriented Polypropylene			
23- Carton sizes (mm)	780*560*600			
24- Carton capacity	28.000 straws			
25- Packing Method	Individually wrapped U-shaped straw in OPP film			
26- OPP heat seal range degree	94	120-140	140	Major
27- Treatment level (ASTM D2578) mN/n		38		Major
28- Haze (ASTM D1003 %)	1.8		2.1	Major
29- Band width (mm)	110	111	112	Critical
30- Boxes per container	252 Cartons (=7,056,000)			

Data Sheet Specification of U-Straw (125 ml)



1- Material:

- Mixture of polypropylene & Master batch.
- Polypropylene is a homopolymer thermoplastic, easy to mold, flows well due to its low melt viscosity & makes a good elastomer.

2- Master Batch:

1.25% additive (Milky White).

3- OPP Film:

OPP is a bi oriented polypropylene transparent film, both sides are heat sealable, good moisture barrier, used for packaging and it complies with FDA regulations.

4- Usage:

U-shaped straw used for drinking of canned juices & soft drinks.

Applies to Tetra Pak & Combibloc Applicators.

5- Packaging:

Each carton box contains 28.000 straws.

Carton dimensions are as follows:

78*56*60 cm

Data Sheet Specification of U-Straw (125 ml)



6- Handling and Storage:

. Precautions for handling

- Ensure good ventilation in the workplace.
- The usual industrial hygiene precautions must be taken during work, in particular: do not drink, eat or smoke during the handling of the product and clean hands and face during work intervals and after work.

. Precautions for storage areas

- Keep carton boxes in a good ventilated place away from direct sunlight.
- Protect from moisture.
- Each column contains no more than 4 carton boxes.

. Expiration Date

Valid for 2 years from production date.

7- Transportation and Delivery:

It must be:

- Transported in a closed clean truck away from direct sunlight.
- Placed in a good position with no more than 4 carton boxes for a column.
- In case of metal ceilings the distance between the product and the metal surface mustn't be less than 3 meters.
- The product temperature must be (15° - 40°) at usage.

Data Sheet Specification of U-Straw (125 ml)



8- Quality Tests & Trials:

- Water involved in the process is filtered and sanitized.
- Measurements are taken during the process such as: length, thickness, diameter and pitch length.
- The product is tested and no microbiological contamination has been found, Specific document is available upon request.

9- Waste Treatment:

Residuals are disposed & not recycled.

10- About us:

Essalam Latex & Plastic Works

New Borg El Arab City

4 th Industrial Zone, Block 34, Area 11, Alexandria, Egypt

Website: www.baron-egypt.com

Emergency contact number

+2 01227352197