

38 Cap Spc.

Technical specification

Dimension	Specification		
	Min.	Target	Max.
Hight	14.3 mm	14.6 mm	14.9 mm
Diameter	38.5 mm	38.7 mm	38.9 mm
Thickness	0.92 mm	0.97 mm	1.03 mm
Weight	3.45 gm	3.55 gm	3.6 gm
Color	Any color is available		
Cap Material	PE (Polyethylene)		
Closing Torque	17-26 NM		
Removal Torque	7-16 NM		
Pull Test	40-55 NM		

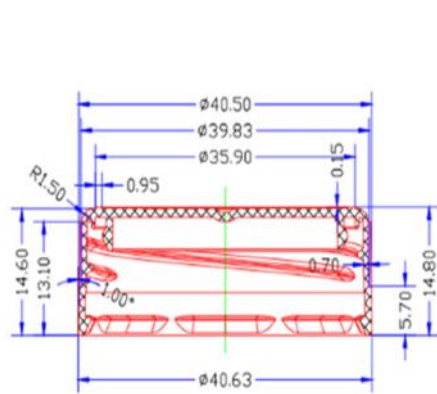

SECTION B-B

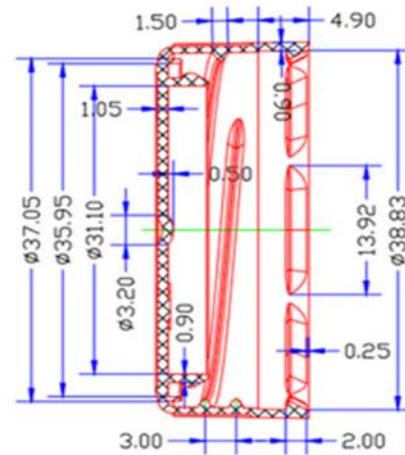

SECTION A-A

1-Material:

High density polyethylene (HDPE) is a thermoplastic polymer with variable crystalline structure and have good low temperature impact resistance and excellent chemical resistance.

2-Master Batch:

M.B granules that have a different percentage according to colour.

3-Usage:

38 Screw caps for dairy bottles.

4-Packaging:

Each carton box contains 4.000 caps surrounded by polyethylene plastic bag.

Carton dimensions are as follows:

60*40*42 cm³

5-Handling and Storage:

. Precautions for handling

- Ensure good ventilation in the workplace.
- The usual industrial hygiene precautions must be taken during work, in particular: do not drink, eat or smoke during the handling of the product and clean hands and face during work intervals and after work.

. Precautions for storage areas

- Keep carton boxes in a good ventilated place away from direct sunlight.
- Protect from moisture.
- Each column contains no more than 5 carton boxes.

6-Transportation and Delivery:

It must be:

- Transported in a closed clean truck away from direct sunlight.
- Placed in a good position with no more than 6 carton boxes for a column.
- In case of metal ceilings the distance between the product and the metal surface mustn't be less than 3 meters.
- The product temperature must be (15° - 40°) at usage.

7-Quality Tests & Trials:

- Measurements are taken during the process such as: length, thickness, diameter and weight.
- Caps are tested for leakage, closing & removal torque and pull force.

8-Waste Treatment:

Residuals are disposed according to legal regulations.

9-About us:

Essalam Latex & Plastic Works

New Borg El Arab City

4 th Industrial Zone, Block 34, Area 11, Alexandria, Egypt

Website: www.baron-egypt.com

Emergency contact number

+2 01227352197